

寸法・重量関係

■クレーン

クレーン容量	12.2mブーム	100,000 kg × 2.8m (13本掛)
	21.1mブーム	50,000 kg × 5.0m (7本掛)
	30.1mブーム	30,000 kg × 6.0m (5本掛)
	39.0mブーム	18,500 kg × 9.0m (4本掛)
	46.2mブーム	12,500 kg × 12.0m (4本掛)
	48.0mブーム	11,200 kg × 12.0m (4本掛)
	9.0mジブ	6,500 kg × 75° (1本掛)
	14.0mジブ	3,500 kg × 73° (1本掛)
19.0mジブ	2,500 kg × 78° (1本掛)	
最大地上揚程	ブーム	48.5m
	ジブ	67.0m
最大作業半径	ブーム	44.0m
	ジブ	48.0m
ブーム長さ		12.2m~48.0m
ブーム伸縮長さ		35.8m
ブーム伸ばし速度		35.8m/110s
ジブ長さ		9.0m~19.0m
ロープ巻上速度	主巻	高速：140 m/min、低速：70 m/min (4層)
	補巻	高速：140 m/min、低速：70 m/min (4層)
フック巻上速度	主巻	高速：10.8 m/min、低速：5.4 m/min (13本掛)
	補巻	高速：140 m/min、低速：70 m/min (1本掛)
ブーム起伏角度		-1.7° ~ 81.5°
ブーム上げ速度		-1.7° ~ 81.5°/55s
旋回角度		360°連続
旋回速度		1.5min ⁻¹ (rpm)
ワイヤロープ	主巻	径22mm×長さ263m 非自転性ワイヤロープ
	補巻	径22mm×長さ150m 非自転性ワイヤロープ
フック		100t吊 (13本掛)、50t吊 (7本掛)、8t吊 (1本掛)
ブーム形式		箱型5段油圧伸縮式、伸縮2方式切換式 伸縮方式Ⅰ…2・3段目同時、4・5段目同時 伸縮方式Ⅱ…2~5段目同時
ブーム伸縮装置		複動油圧シリンダ直押し 3本、ワイヤロープ伸縮装置 1基 圧力補償付流量調整弁付
ジブ形式		ブーム横折格納式、3段油圧同時伸縮式 オフセット5°~60°油圧無段階傾斜式
シングルトップ		先端ブーム取付横折格納式
巻上装置		油圧モータ駆動遊星歯車減速式、自動ブレーキ シングルウインチ2基、圧力補償付流量調整弁付
ブーム起伏装置		複動油圧シリンダ直押し 1本、圧力補償付流量調整弁付
旋回装置		油圧モータ駆動遊星歯車減速式、スイングベアリング式 手動スイッチ式ブレーキ、旋回フリー・ロック切換式
アウトリガ		全油圧式 H型、スライドジャッキ各個操作装置付 最大張出幅7.2m、中間張出幅6.36m、4.9m、4.0m スライド格納式フロート
作業時最大路面荷重		80 t
動力取出方式	上部専用エンジン	
	名称	三菱 6D16-TE1
	形式	水冷4サイクル直列6気筒 直接噴射式ディーゼルエンジン
	総排気量	7.54 L
	最高出力	126kW (171 PSI) / 1,830 min ⁻¹
最大トルク	687N・m (70.0kgf・m) / 1,600min ⁻¹	
油圧ポンプ	高圧可変ピストンポンプ 2連+高圧ギヤポンプ 2連	
作動油タンク容量	1010 L	

安全装置	過負荷防止装置 (AML) 作業範囲制限機能付、フック移動量表示機能付 アウトリガ張出幅自動検出装置 (個別検出式)、ウエイト組合せ自動検出装置、旋回範囲制御装置、旋回自動停止機能付、ブーム起伏停止機能付、巻過防止装置、捨巻確保装置、水準器、玉掛けロープはずれ止め、乱巻防止装置、ウインチドラムロック装置、旋回ロック装置、油圧安全弁、伸縮シリンダ油圧ロック装置、起伏シリンダ油圧ロック装置、ジャッキシリンダ油圧ロック装置
付属装置	カウンタウエイト脱着装置、ジブ張出装置、ブーム起伏微速モード設定装置、旋回微速モード設定装置、旋回体脱着装置 (脱着リング)、AML外部表示灯、オイルクーラ、クレーンキャブエアコン、FM付ラジオ、ホット&クールボックス、ランチテーブル、ドラム視認モニター、旋回音声警報装置
オプション	TVチューナー、旋回体脱着装置 (脱着リフター)、拡声器

■キャリヤ

メーカー名	FAUN GmbH	
キャリヤ型式	RTF 101-4	
エンジン	型式	OM501LA (ベンツ製) 水冷4サイクルV型6気筒直接噴射式 インタークーラ付ターボディーゼルエンジン
	総排気量	11.946 L
	最高出力	315kW (428 PSI) / 1,800 rpm
	最大トルク	2,000 N・m (204kgf・m) / 1,080 rpm
変速機形式	フルオートマチック、前進6段、後退1段、副変速機付	
クラッチ形式	トルクコンバータ付、自動ロックアップ機構付	
駆動方式	8×6	
車軸形式 (全軸)	全浮動式	
懸架方式 (全軸)	ハイドロニューマチックサスペンション サスペンションストローク +151mm -125mm	
ステアリング	形式	左ハンドル、全油圧式パワーステアリング、2系統式、非常用パワーステアリング
	モード	ノーマル (前4輪)、クランプ (8輪)、クラブ (8輪)、リヤステ (後4輪)
ブレーキ	主ブレーキ	空気式全輪制動、2系統式
	駐車ブレーキ	2・3・4軸 (6輪) 制動 スプリング式
	非常ブレーキ	駐車ブレーキと兼用
	補助ブレーキ	電気式リタダー
バッテリー	12V-170Ah×2個 (24V)	
燃料タンク容量	400L	
乗車定員	2人	
タイヤ	445/95R25 177E ROAD (全輪)	
ホイール	11.00-25 (全輪)	
付属装置	カーエアコン、FM付ラジオ、マッドガード、集中給油装置、仮眠用ベッド、バックモニタカメラ	

■走行時寸法・重量 (台車のみ)

全長	10,815mm	
全幅	2,780mm	
全高	3,075mm	
軸距	1,690mm+2,305mm+1,700mm=5,695mm	
輪距	2,310mm	
車両総重量	全重量	24,630kg (人員2名)
	前軸重	13,180kg
	後軸重	11,450kg

■走行性能

最高速度	63km/h	
登坂能力 (tanθ)	1.13	
最小回転半径	4輪ステアリング	11.2m
	8輪ステアリング	7.0m

寸法・重量関係

■ 構内走行状態

単位(mm)

縮尺1/100

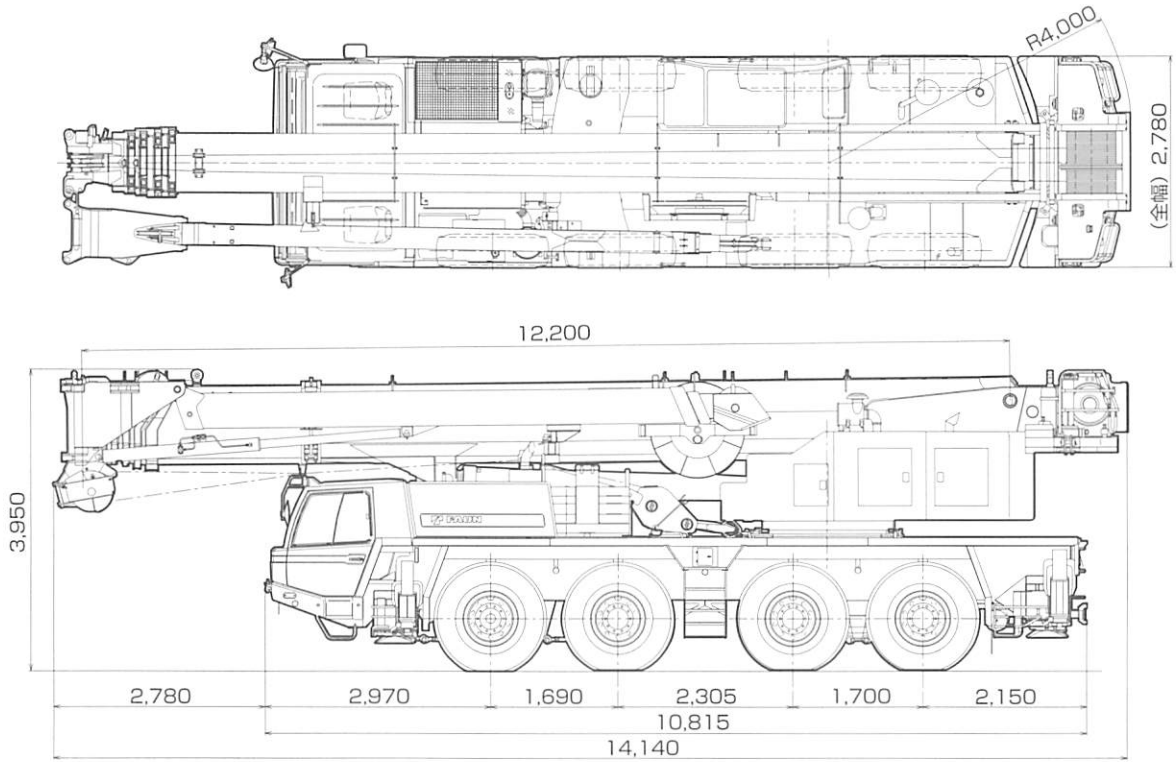

■ 公道走行状態

単位(mm)

縮尺1/100

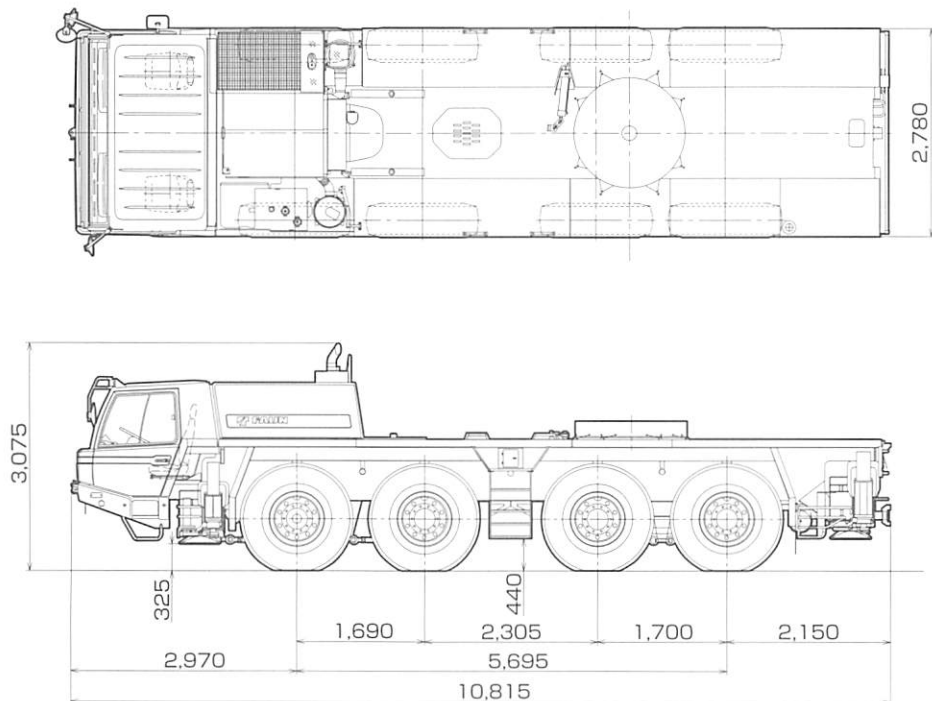

(注意) 1.本機は、公道を走行する場合には、旋回体及びブームを別送し、台車のみで走行しなければなりません。
2.道路法による基本通行条件のA条件適合車です。

寸法・重量関係

単位(mm)

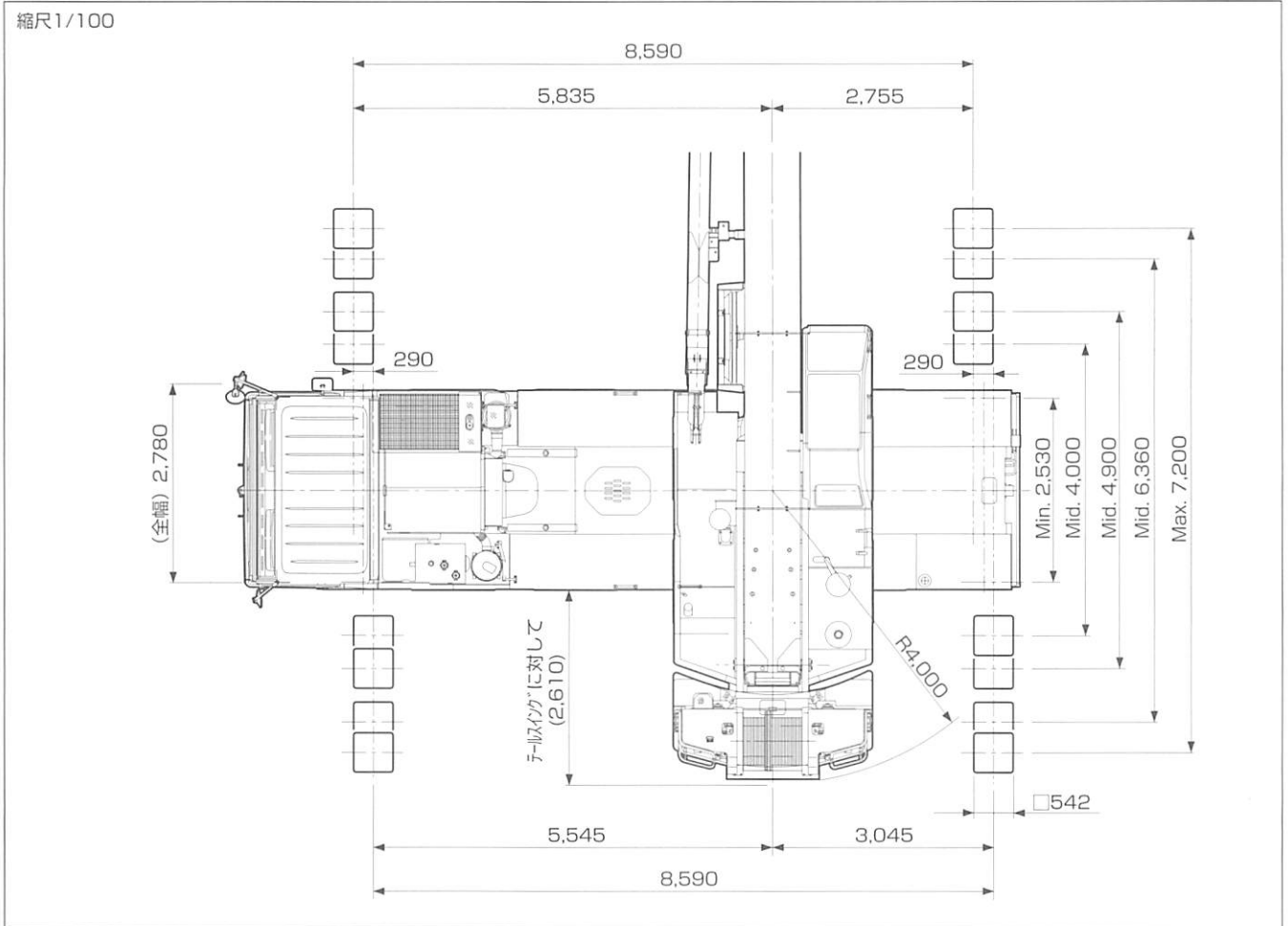

■ 最小直角通路幅

単位(mm)

ノーマルステアリング (前4輪)

クランプステアリング (8輪)

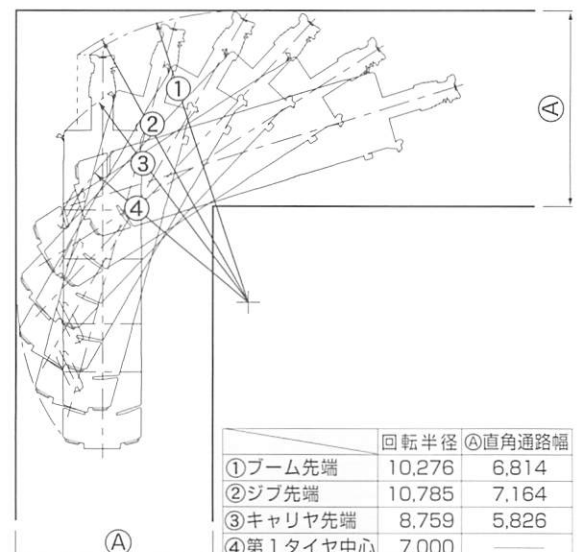
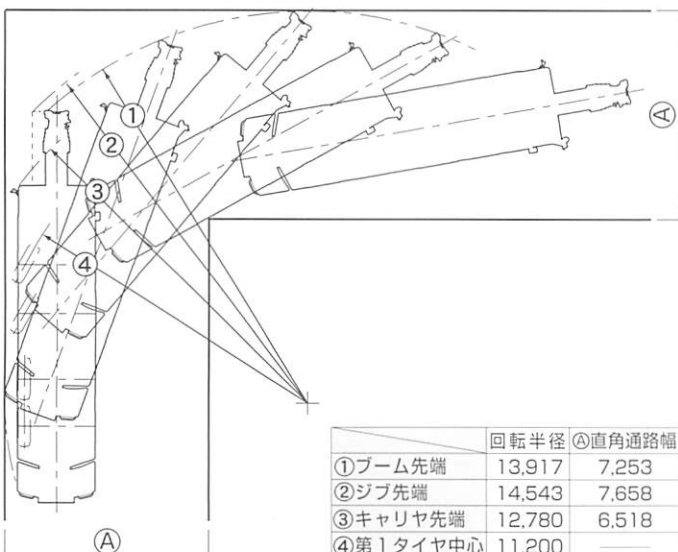

寸法・重量関係

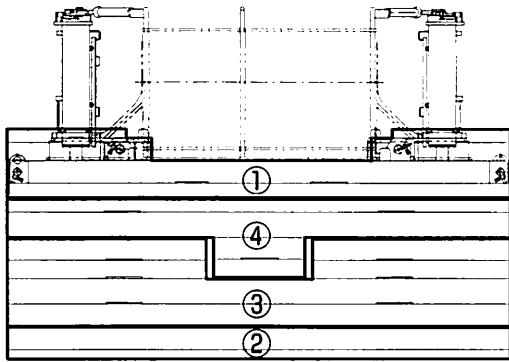

■カウンタウエイト質量表

ウエイト	質量
①	5t
②	4t
③	7t
④	5t

■カウンタウエイト組合せ表

ウエイト呼び	組合せ
21t	①+②+③+④
16t	①+②+③
9t	①+②
5t	①

■カウンタウエイト寸法図

単位(mm)

① 固定ウエイト 5t

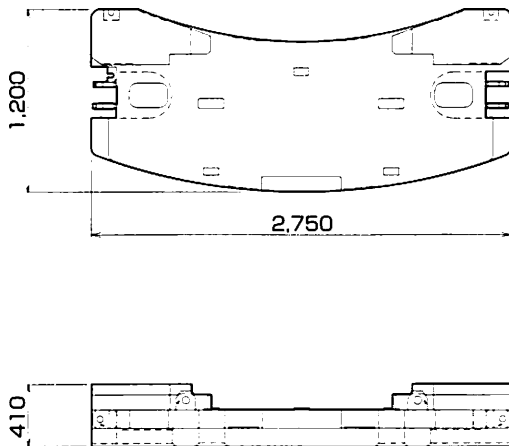

② STDウエイト 4t

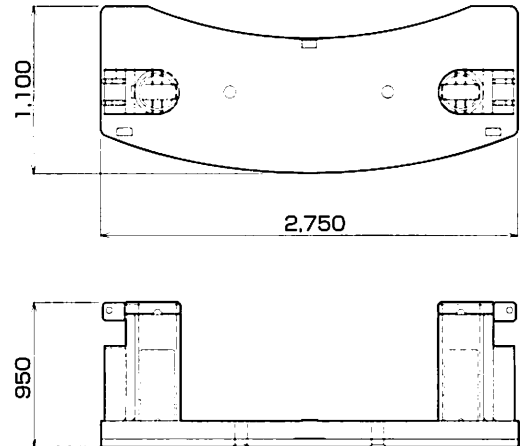

③ STDウエイト 7t

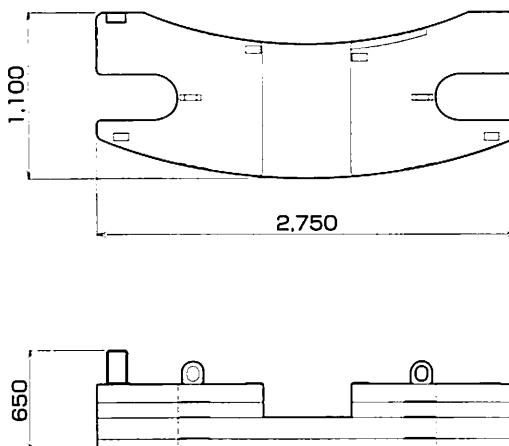

④ EXTウエイト 5t

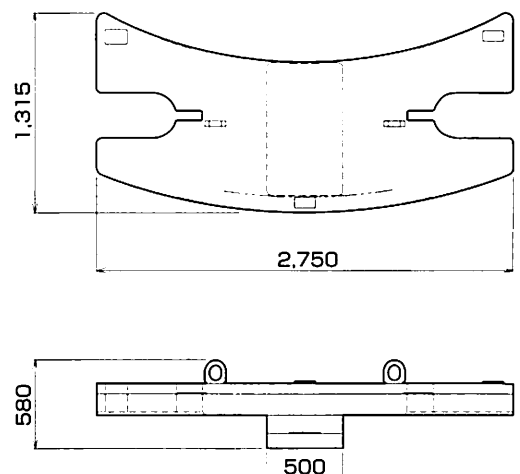

■上部旋回体搬送状態（ブーム・旋回台、約28 t）

単位(mm)

リフト幅 2,992

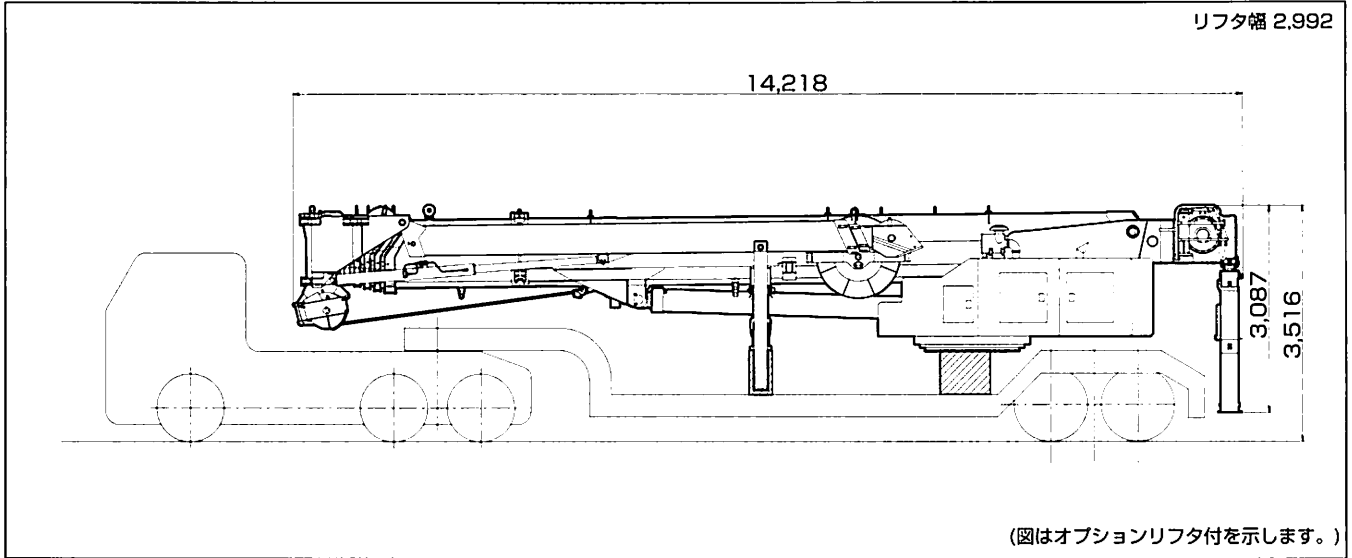

■カウンタウイト搬送状態（約21 t）

単位(mm)

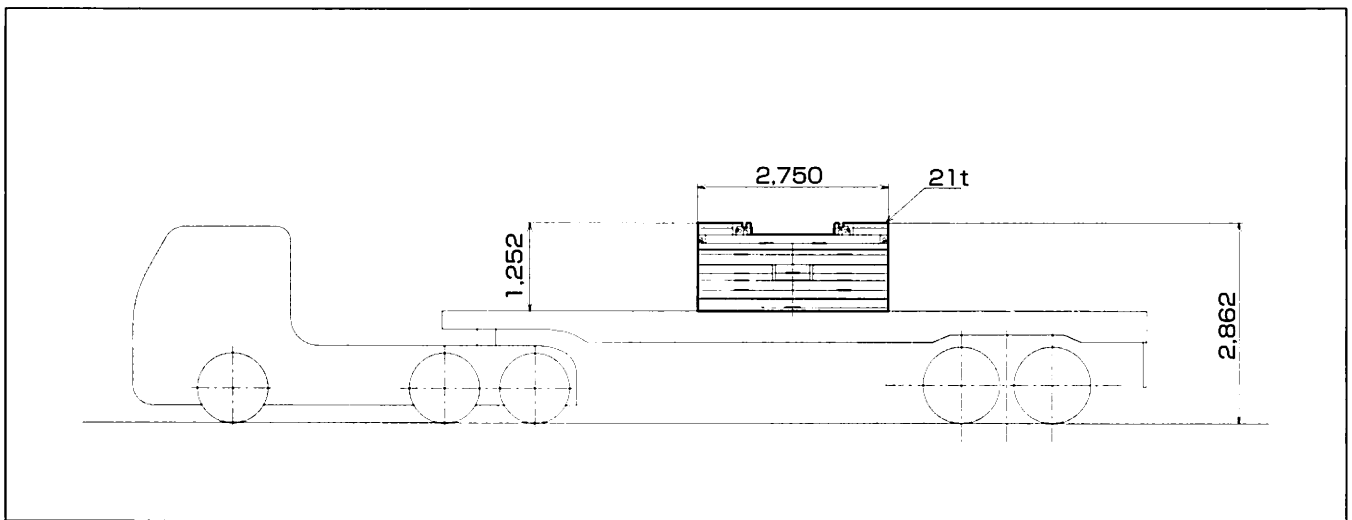

■キャリヤ公道走行状態（約24.63 t）

単位(mm)

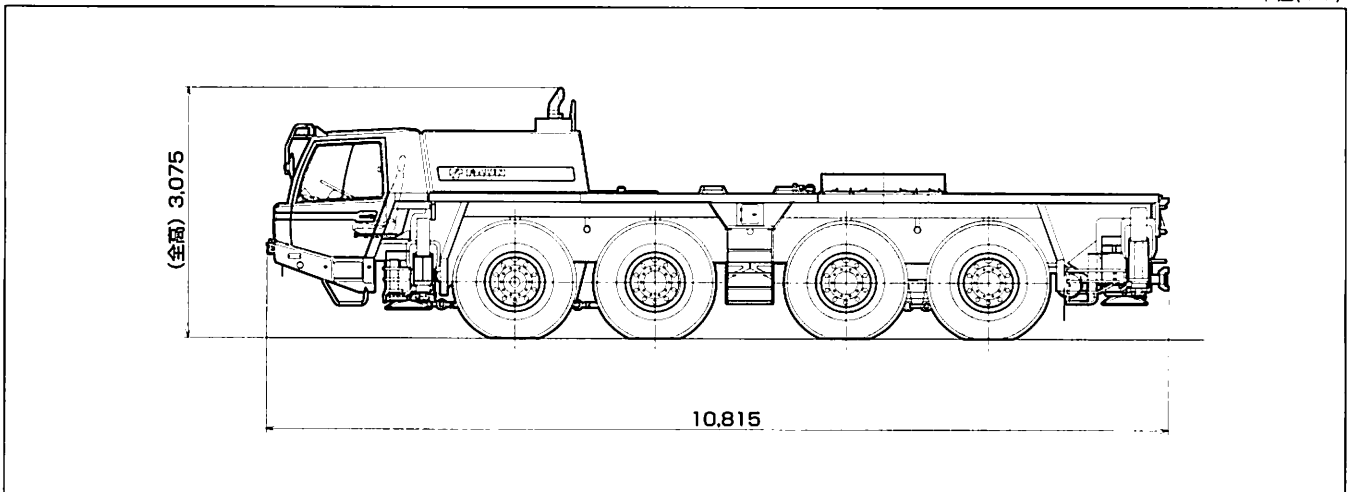

■ A性能 (カウンタウエイト 21t) アウトリガ張出幅 7.2m

単位: t

ブーム長さ 作業半径 (m)	12.2m	21.1m	30.1m	39.0m	46.2m	48.0m
2.8	100.0	50.0	19.5			
3.0	95.6	50.0	19.5			
3.5	86.6	50.0	19.5			
4.0	75.5	50.0	19.5			
4.5	66.7	50.0	19.5	30.0	19.5	
5.0	59.6	50.0	19.5	30.0	19.5	
6.0	48.7	48.9	19.5	30.0	19.5	
7.0	40.7	41.0	19.5	28.9	19.5	18.5 17.3
8.0	34.7	34.9	19.5	25.9	19.5	18.5 17.3
9.0	30.0	30.2	19.5	23.3	19.5	18.5 17.3 12.5 11.2
10.0		26.4	19.5	21.1	19.5	18.2 16.2 12.5 11.2
12.0		20.6	19.5	17.7	18.2	15.3 14.1 12.5 11.2
14.0		15.5	17.0	15.0	16.6	13.0 12.4 11.3 10.7
16.0		12.0	13.4	12.0	13.9	11.2 11.1 9.9 9.5
18.0		9.5	10.8	9.4	11.3	9.7 9.8 8.7 8.4
20.0				7.5	9.3	8.5 8.8 7.8 7.4
22.0				6.0	7.7	7.2 7.8 7.0 6.7
24.0				4.7	6.4	5.9 6.6 6.2 6.0
26.0				3.7	5.4	4.9 5.5 5.4 5.4
28.0					4.0	4.6 4.6 4.7
30.0					3.3	3.9 3.8 3.9
32.0					2.7	3.3 3.2 3.3
34.0					2.1	2.7 2.6 2.7
36.0					1.7	2.3 2.2 2.3
38.0						1.8 1.8
40.0						1.4 1.5
42.0						1.1 1.2
44.0						1.0
$\theta(^{\circ})$	0~81.5	0~81.5	0~81.5	0~81.5	0~81.5	0~81.5 11~81.5
各ブーム段の伸長状態 (%)						
伸縮方式	I, II	I	II	I	II	I, II
2段目ブーム	0	50	25	100	50	100 100
3段目ブーム	0	50	25	100	50	100 100
4段目ブーム	0	0	25	0	50	75 90 100
5段目ブーム	0	0	25	0	50	75 90 100

■ B性能 (カウンタウエイト 16t) アウトリガ張出幅 7.2m

単位: t

ブーム長さ 作業半径 (m)	12.2m	21.1m	30.1m	39.0m	46.2m	48.0m
2.8	100.0	50.0	19.5			
3.0	95.6	50.0	19.5			
3.5	83.0	50.0	19.5			
4.0	72.3	50.0	19.5			
4.5	63.8	50.0	19.5	30.0	19.5	
5.0	56.9	50.0	19.5	30.0	19.5	
6.0	46.4	46.7	19.5	30.0	19.5	
7.0	38.8	39.0	19.5	28.9	19.5	18.5 17.3
8.0	33.1	33.3	19.5	25.9	19.5	18.5 17.3
9.0	28.5	28.7	19.5	23.3	19.5	18.5 17.3 12.5 11.2
10.0		25.1	19.5	21.1	19.5	18.2 16.2 12.5 11.2
12.0		17.9	19.5	17.7	18.2	15.3 14.1 12.5 11.2
14.0		13.3	14.7	13.2	15.2	13.0 12.4 11.3 10.7
16.0		10.1	11.5	10.1	12.0	11.2 11.1 9.9 9.5
18.0		7.8	9.2	7.8	9.6	9.1 9.8 8.7 8.4
20.0				6.0	7.8	7.3 8.0 7.8 7.4
22.0				4.6	6.4	5.9 6.5 6.5 6.6
24.0				3.5	5.2	4.7 5.4 5.3 5.4
26.0				2.7	4.3	3.8 4.4 4.4 4.5
28.0					3.0	3.7 3.6 3.7
30.0					2.4	3.0 2.9 3.0
32.0					1.8	2.4 2.3 2.4
34.0					1.3	2.0 1.8 1.9
36.0					1.0	1.6 1.4 1.5
38.0						1.0 1.1
$\theta(^{\circ})$	0~81.5	0~81.5	0~81.5	0~81.5	0~81.5	28~81.5 31~81.5
各ブーム段の伸長状態 (%)						
伸縮方式	I, II	I	II	I	II	I, II
2段目ブーム	0	50	25	100	50	100 100
3段目ブーム	0	50	25	100	50	100 100
4段目ブーム	0	0	25	0	50	75 90 100
5段目ブーム	0	0	25	0	50	75 90 100

■ C性能 (カウンタウエイト 21t) アウトリガ張出幅 6.36m

単位: t

ブーム長さ 作業半径 (m)	12.2m	21.1m	30.1m	39.0m	46.2m	48.0m
2.8	85.0	50.0	19.5			
3.0	81.5	50.0	19.5			
3.5	73.7	50.0	19.5			
4.0	67.1	50.0	19.5			
4.5	61.4	50.0	19.5	30.0	19.5	
5.0	56.5	50.0	19.5	30.0	19.5	
6.0	48.3	48.5	19.5	30.0	19.5	
7.0	40.7	41.0	19.5	28.9	19.5	18.5 17.3
8.0	34.7	34.9	19.5	25.9	19.5	18.5 17.3
9.0	30.0	30.2	19.5	23.3	19.5	18.5 17.3 12.5 11.2
10.0		26.4	19.5	21.1	19.5	18.2 16.2 12.5 11.2
12.0		20.4	19.5	17.7	18.2	15.3 14.1 12.5 11.2
14.0		15.4	16.8	15.0	16.6	13.0 12.4 11.3 10.7
16.0		11.9	13.3	11.8	13.7	11.2 11.1 9.9 9.5
18.0		9.4	10.7	9.3	11.1	9.7 9.8 8.7 8.4
20.0				7.3	9.1	8.5 8.8 7.8 7.4
22.0				5.6	7.6	7.1 7.7 7.0 6.7
24.0				4.3	6.3	5.8 6.5 6.2 6.0
26.0				3.2	5.3	4.6 5.4 5.3 5.4
28.0					3.7	4.4 4.4 4.5
30.0					2.8	3.6 3.5 3.7
32.0					2.2	2.9 2.8 3.0
34.0					1.6	2.3 2.2 2.3
36.0					1.1	1.8 1.7 1.8
38.0						1.2 1.3
40.0						0.9
$\theta(^{\circ})$	0~81.5	0~81.5	0~81.5	0~81.5	0~81.5	27~81.5 28~81.5
各ブーム段の伸長状態 (%)						
伸縮方式	I, II	I	II	I	II	I, II
2段目ブーム	0	50	25	100	50	100 100
3段目ブーム	0	50	25	100	50	100 100
4段目ブーム	0	0	25	0	50	75 90 100
5段目ブーム	0	0	25	0	50	75 90 100

■ D性能 (カウンタウエイト 16t) アウトリガ張出幅 6.36m

単位: t

ブーム長さ 作業半径 (m)	12.2m	21.1m	30.1m	39.0m	46.2m	48.0m
2.8	84.3	50.0	19.5			
3.0	80.8	50.0	19.5			
3.5	73.0	50.0	19.5			
4.0	66.4	50.0	19.5			
4.5	60.7	50.0	19.5	30.0	19.5	
5.0	55.7	50.0	19.5	30.0	19.5	
6.0	46.4	46.7	19.5	30.0	19.5	
7.0	38.8	39.0	19.5	28.9	19.5	18.5 17.3
8.0	33.1	33.3	19.5	25.9	19.5	18.5 17.3
9.0	28.5	28.7	19.5	23.3	19.5	18.5 17.3 12.5 11.2
10.0		24.9	19.5	21.1	19.5	18.2 16.2 12.5 11.2
12.0		17.6	19.2	17.6	18.2	15.3 14.1 12.5 11.2
14.0		13.1	14.6	13.1	15.1	13.0 12.4 11.3 10.7
16.0		10.0	11.4	9.9	11.8	11.2 11.1 9.9 9.5
18.0		7.7	9.0	7.6	9.5	9.0 9.6 8.7 8.4
20.0				5.7	7.7	7.2 7.8 7.8 7.4
22.0				4.2	6.3	5.7 6.4 6.4 6.5
24.0				3.0	5.1	4.5 5.3 5.2 5.3
26.0				2.0	4.1	3.4 4.2 4.1 4.3
28.0					2.6	3.4 3.3 3.4
30.0					1.8	2.6 2.5 2.7
32.0					1.2	2.0 1.9 2.0
34.0						1.4 1.3 1.5
36.0						1.0 1.0
$\theta(^{\circ})$	0~81.5	0~81.5	0~81.5	0~81.5	0~81.5	25~81.5 38~81.5 38~81.5
各ブーム段の伸長状態 (%)						
伸縮方式	I, II	I	II	I	II	I, II
2段目ブーム	0	50	25	100	50	100 100
3段目ブーム	0	50	25	100	50	100 100
4段目ブーム	0	0	25	0	50	75 90 100
5段目ブーム	0	0	25	0	50	75 90 100

ブーム

E性能

(カウンタウエイト 9t)
(アウトリガ張出幅 7.2m)
(カウンタウエイト 21t)
(アウトリガ張出幅 4.9m)

単位: t

ブーム長さ 作業半径(m)	12.2m	21.1m	30.1m	39.0m	46.2m	48.0m
2.8	79.2	50.0	19.5			
3.0	75.6	50.0	19.5			
3.5	67.8	50.0	19.5			
4.0	61.3	50.0	19.5			
4.5	55.7	50.0	19.5	30.0	19.5	
5.0	50.9	50.0	19.5	30.0	19.5	
6.0	43.1	43.3	19.5	30.0	19.5	
7.0	36.0	36.2	19.5	28.9	19.5	18.5
8.0	29.8	30.0	19.5	25.9	19.5	18.5
9.0	24.1	24.3	19.5	23.3	19.5	18.5
10.0		19.8	19.5	19.8	19.5	18.2
12.0		13.7	15.3	13.7	15.9	15.3
14.0		9.9	11.4	9.9	11.9	11.3
16.0		7.3	8.7	7.2	9.1	8.6
18.0		5.4	6.7	5.3	7.1	6.6
20.0				3.9	5.6	5.1
22.0				2.7	4.4	4.0
24.0				1.8	3.5	3.0
26.0				1.0	2.7	2.2
28.0					1.6	2.2
30.0					1.0	1.6
32.0						1.2
$\theta(^{\circ})$	0~81.5	0~81.5	0~81.5	12~81.5	0~81.5	34~81.5

各ブーム段の伸長状態(%)

伸縮方式	I, II	I	II	I	II	I	II	I	I, II
2段目ブーム	0	50	25	100	50	100	75	100	100
3段目ブーム	0	50	25	100	50	100	75	100	100
4段目ブーム	0	0	25	0	50	50	75	90	100
5段目ブーム	0	0	25	0	50	50	75	90	100

F性能

(カウンタウエイト 9t)
(アウトリガ張出幅 6.36m)
(カウンタウエイト 16t)
(アウトリガ張出幅 4.9m)

単位: t

ブーム長さ 作業半径(m)	12.2m	21.1m	30.1m	39.0m	46.2m	48.0m
2.8	74.4	50.0	19.5			
3.0	70.8	50.0	19.5			
3.5	63.1	50.0	19.5			
4.0	56.6	50.0	19.5			
4.5	51.2	50.0	19.5	30.0	19.5	
5.0	46.6	46.8	19.5	30.0	19.5	
6.0	38.4	38.7	19.5	30.0	19.5	
7.0	29.3	29.6	19.5	28.9	19.5	18.5
8.0	23.2	23.4	19.5	23.4	19.5	18.5
9.0	18.9	19.1	19.5	19.1	19.5	18.5
10.0		15.8	17.3	15.8	17.8	17.2
12.0		11.2	12.6	11.2	13.1	12.6
14.0		8.2	9.5	8.2	10.0	9.5
16.0		5.9	7.3	5.8	7.7	7.3
18.0		4.1	5.6	4.0	6.1	5.5
20.0				2.6	4.7	4.1
22.0				1.5	3.5	2.9
24.0					2.6	2.0
26.0					1.8	1.2
28.0						1.3
$\theta(^{\circ})$	0~81.5	0~81.5	0~81.5	34~81.5	0~81.5	45~81.5

各ブーム段の伸長状態(%)

伸縮方式	I, II	I	II	I	II	I	II	I	I, II
2段目ブーム	0	50	25	100	50	100	75	100	100
3段目ブーム	0	50	25	100	50	100	75	100	100
4段目ブーム	0	0	25	0	50	50	75	90	100
5段目ブーム	0	0	25	0	50	50	75	90	100

注) *印は、カウンタウエイト21t、アウトリガ張出幅4.0mの場合を示す。

G性能

(カウンタウエイト 16t)
(アウトリガ張出幅 4.0m)
(カウンタウエイト 0t)
(アウトリガ張出幅 7.2m)

単位: t

ブーム長さ 作業半径(m)	12.2m	21.1m	30.1m	39.0m	46.2m	48.0m
2.8	72.8	50.0	19.5			
3.0	69.2	50.0	19.5			
3.5	61.6	50.0	19.5			
4.0	55.2	50.0	19.5			
4.5	49.9	50.0	19.5	30.0	19.5	
5.0	45.3	45.5	19.5	30.0	19.5	
6.0	33.4	33.7	19.5	30.0	19.5	
7.0	25.3	25.6	19.5	25.6	19.5	18.5
8.0	19.9	20.1	19.5	20.1	19.5	18.5
9.0	15.9	16.1	17.8	16.1	18.3	17.7
10.0		13.0	14.6	13.0	15.1	14.6
12.0		8.5	10.1	8.5	10.6	10.0
14.0		5.6	7.1	5.5	7.6	7.1
16.0		3.3	5.0	3.3	5.5	5.0
18.0		1.7	3.4	1.7	3.9	3.3
20.0					2.6	2.9
22.0					1.6	1.8
$\theta(^{\circ})$	0~81.5	0~81.5	0~81.5	49~81.5	29~81.5	60~81.5

各ブーム段の伸長状態(%)

伸縮方式	I, II	I	II	I	II	I	II	I	I, II
2段目ブーム	0	50	25	100	50	100	75	100	100
3段目ブーム	0	50	25	100	50	100	75	100	100
4段目ブーム	0	0	25	0	50	50	75	90	100
5段目ブーム	0	0	25	0	50	50	75	90	100

注) *印は、カウンタウエイト16t、アウトリガ張出幅4.0mの場合を示す。

H性能

(カウンタウエイト 9t)
(アウトリガ張出幅 4.0m)
(カウンタウエイト 0t)
(アウトリガ張出幅 4.9m)

単位: t

ブーム長さ 作業半径(m)	12.2m	21.1m
2.8	25.0	25.0
3.0	25.0	25.0
3.5	25.0	25.0
4.0	25.0	25.0
4.5	25.0	25.0
5.0	25.0	25.0
6.0	17.0	17.3
7.0	12.1	12.4
8.0	8.9	9.2
9.0	6.6	6.8
10.0		5.0
12.0		2.3
14.0		
$\theta(^{\circ})$	0~81.5	47~81.5

各ブーム段の伸長状態(%)

伸縮方式	I, II	I	II
2段目ブーム	0	50	25
3段目ブーム	0	50	25
4段目ブーム	0	0	25
5段目ブーム	0	0	25

I性能

(カウンタウエイト 0t)
(アウトリガ張出幅 2.53m)

単位: t

ブーム長さ 作業半径(m)	12.2m
2.8	8.5
3.0	8.5
3.5	8.5
4.0	8.5
4.5	8.5
5.0	8.5
6.0	8.0
7.0	5.3
8.0	3.2
9.0	1.6
$\theta(^{\circ})$	0~75

各ブーム段の伸長状態(%)

伸縮方式	I, II
2段目ブーム	0
3段目ブーム	0
4段目ブーム	0
5段目ブーム	0

フルオートジブ

■ A性能 46.2mブーム+フルオートジブ (カウンタウエイト 21t アウトリガ張出幅 7.2m)

単位: t

ジブ長さ オフセット	9.0mジブ								14.0mジブ							
	5°		25°		45°		60°		5°		25°		45°		60°	
ブーム角度(°)	作業半径m	荷重	作業半径m	荷重	作業半径m	荷重	作業半径m	荷重	作業半径m	荷重	作業半径m	荷重	作業半径m	荷重	作業半径m	荷重
81.5	7.6	6.5	10.2	5.65	12.0	4.7	12.7	4.4	8.8	3.5	13.1	2.9	15.9	2.15	17.2	1.9
80	9.9	6.5	12.3	5.65	13.9	4.7	14.6	4.4	11.2	3.5	15.3	2.9	18.0	2.15	19.1	1.9
79	10.9	6.5	13.4	5.65	14.9	4.7	15.6	4.4	12.3	3.5	16.4	2.9	19.0	2.15	20.1	1.9
78	12.0	6.5	14.4	5.65	15.9	4.7	16.5	4.4	13.5	3.5	17.5	2.9	20.0	2.15	21.0	1.9
75	15.3	6.5	17.3	4.95	18.6	4.2	19.1	4.0	17.0	3.5	20.7	2.75	22.9	2.05	23.7	1.85
73	17.2	5.9	19.2	4.55	20.4	3.95	20.8	3.8	19.2	3.5	22.7	2.65	24.8	2.0	25.5	1.85
70	20.1	5.1	21.9	4.05	23.0	3.6	23.3	3.5	22.4	3.2	25.7	2.5	27.5	1.95	28.1	1.85
68	21.9	4.6	23.7	3.8	24.7	3.4	24.9	3.3	24.4	2.95	27.6	2.4	29.3	1.9	29.7	1.8
65	24.5	3.95	26.2	3.4	27.1	3.1	27.3	3.1	27.4	2.7	30.4	2.25	31.9	1.9	32.1	1.8
63	26.2	3.55	27.9	3.15	28.7	2.95	28.8	2.95	29.3	2.55	32.2	2.2	33.5	1.85	33.6	1.8
60	28.7	3.0	30.3	2.8	31.0	2.65			32.1	2.35	34.7	2.0	35.9	1.8		
58	30.3	2.7	31.8	2.5	32.4	2.45			33.9	2.2	36.4	1.9	37.4	1.75		
55	32.6	2.3	34.0	2.15	34.5	2.1			36.4	1.9	38.7	1.7	39.5	1.65		
53	34.0	1.9	35.3	1.8	35.7	1.75			38.0	1.6	40.1	1.5	40.8	1.45		
50	36.0	1.25	37.2	1.2	37.5	1.2			40.1	1.05	42.1	1.0	42.6	0.95		
48	37.3	0.9	38.4	0.85	38.7	0.85			41.4	0.75	43.3	0.7	43.7	0.65		
θ(°)	47~81.5		47~81.5		47~81.5		62~81.5		47~81.5		47~81.5		47~81.5		62~81.5	

ジブ長さ オフセット	19.0mジブ							
	5°		25°		45°		60°	
ブーム角度(°)	作業半径m	荷重	作業半径m	荷重	作業半径m	荷重	作業半径m	荷重
81.5	10.2	2.5	15.8	1.3	19.9	0.9	21.8	0.8
80	12.8	2.5	18.2	1.3	22.0	0.9	23.7	0.8
79	14.1	2.5	19.3	1.3	23.1	0.9	24.7	0.8
78	15.4	2.5	20.5	1.3	24.1	0.9	25.6	0.8
75	19.0	2.3	23.8	1.2	27.2	0.9	28.4	0.8
73	21.3	2.1	26.0	1.15	29.1	0.85	30.2	0.75
70	24.7	1.85	29.1	1.1	32.0	0.85	32.7	0.75
68	26.9	1.7	31.2	1.05	33.8	0.8	34.4	0.75
65	30.1	1.55	34.1	1.0	36.4	0.8	36.8	0.75
63	32.2	1.45	36.0	0.95	38.1	0.8	38.3	0.75
60	35.3	1.35	38.8	0.9	40.5	0.75		
58	37.2	1.25	40.6	0.9	42.1	0.75		
55	40.0	1.15	43.1	0.85	44.3	0.75		
53	41.8	1.1	44.7	0.85	45.6	0.75		
50	44.3	0.95	47.0	0.8	47.6	0.75		
48	45.7	0.65						
θ(°)	47~81.5		49~81.5		49~81.5		62~81.5	

■ A性能 48.0mブーム+フルオートジブ (カウンタウエイト 21t アウトリガ張出幅 7.2m)

単位: t

ジブ長さ オフセット	9.0mジブ								14.0mジブ							
	5°		25°		45°		60°		5°		25°		45°		60°	
ブーム角度(°)	作業半径m	荷重	作業半径m	荷重	作業半径m	荷重	作業半径m	荷重	作業半径m	荷重	作業半径m	荷重	作業半径m	荷重	作業半径m	荷重
81.5	7.9	5.2	10.6	5.0	12.3	4.1	13.0	3.8	9.2	3.5	13.5	2.9	16.4	2.15	17.7	1.9
80	10.1	5.2	12.8	5.0	14.3	4.1	15.0	3.8	11.7	3.5	15.9	2.9	18.5	2.15	19.6	1.9
79	11.3	5.2	13.8	5.0	15.4	4.1	16.0	3.8	12.9	3.5	17.0	2.9	19.6	2.15	20.6	1.9
78	12.4	5.2	14.9	4.95	16.4	4.05	16.9	3.8	14.1	3.5	18.2	2.9	20.6	2.15	21.6	1.9
75	15.7	5.2	17.8	4.2	19.2	3.55	19.6	3.35	17.8	3.5	21.4	2.7	23.6	2.05	24.4	1.85
73	17.8	4.9	19.8	3.8	21.0	3.25	21.4	3.1	20.1	3.5	23.5	2.55	25.6	2.0	26.3	1.85
70	20.7	4.1	22.6	3.3	23.7	2.9	24.0	2.8	23.3	2.95	26.5	2.2	28.4	1.85	28.9	1.75
68	22.6	3.65	24.4	3.0	25.4	2.65	25.7	2.6	25.3	2.65	28.4	2.0	30.2	1.7	30.6	1.65
65	25.4	3.15	27.0	2.6	27.9	2.35	28.1	2.35	28.3	2.25	31.2	1.75	32.8	1.55	33.0	1.5
63	27.1	2.85	28.8	2.4	29.6	2.2	29.6	2.2	30.2	2.05	33.0	1.6	34.4	1.4	34.5	1.4
60	29.7	2.45	31.2	2.1	31.9	1.95			33.1	1.75	35.6	1.4	36.9	1.3		
58	31.4	2.25	32.9	1.95	33.5	1.85			34.9	1.6	37.3	1.3	38.4	1.2		
55	33.8	1.9	35.2	1.75	35.6	1.65			37.5	1.4	39.7	1.15	40.6	1.1		
53	35.3	1.55	36.6	1.55	37.0	1.5			39.2	1.25	41.3	1.05	42.0	1.0		
50	37.4	0.95	38.6	0.95	38.9	0.95			41.4	0.8	43.4	0.75	43.9	0.7		
48	38.7	0.6	39.8	0.6	40.0	0.6										
θ(°)	47~81.5		47~81.5		47~81.5		62~81.5		49~81.5		49~81.5		49~81.5		62~81.5	

ジブ長さ オフセット	19.0mジブ							
	5°		25°		45°		60°	
ブーム角度(°)	作業半径m	荷重	作業半径m	荷重	作業半径m	荷重	作業半径m	荷重
81.5	10.6	2.2	16.3	1.3	20.3	0.9	22.2	0.8
80	13.2	2.2	18.7	1.3	22.5	0.9	24.2	0.8
79	14.5	2.2	19.9	1.3	23.6	0.9	25.2	0.8
78	15.9	2.2	21.1	1.3	24.7	0.9	26.2	0.8
75	19.7	2.2	24.5	1.2	27.8	0.85	29.1	0.8
73	22.1	2.0	26.8	1.15	29.9	0.85	30.9	0.75
70	25.7	1.8	30.0	1.05	32.8	0.8	33.6	0.75
68	27.9	1.65	32.2	1.05	34.7	0.8	35.3	0.75
65	31.2	1.5	35.2	0.95	37.5	0.8	37.8	0.75
63	33.4	1.4	37.2	0.95	39.2	0.75	39.4	0.75
60	36.5	1.3	40.0	0.9	41.7	0.75		
58	38.5	1.2	41.8	0.85	43.3	0.75		
55	41.3	1.05	44.4	0.8	45.6	0.75		
53	43.1	0.95	46.0	0.75	47.0	0.7		
50	45.6	0.7	48.3	0.6				
48								
θ(°)	49~81.5		49~81.5		52~81.5		62~81.5	

■B性能 46.2mブーム+フルオートジブ (カウンタウエイト 16t
アウトリガ張出幅 7.2m)

単位: t

ジブ長さ	9.0mジブ								14.0mジブ							
	5°		25°		45°		60°		5°		25°		45°		60°	
オフセット	作業半径m	荷重	作業半径m	荷重	作業半径m	荷重	作業半径m	荷重	作業半径m	荷重	作業半径m	荷重	作業半径m	荷重	作業半径m	荷重
81.5	7.6	6.5	10.2	5.65	12.0	4.7	12.7	4.4	8.8	3.5	13.1	2.9	15.9	2.15	17.2	1.9
80	9.9	6.5	12.3	5.65	13.9	4.7	14.6	4.4	11.2	3.5	15.3	2.9	18.0	2.15	19.1	1.9
79	10.9	6.5	13.4	5.65	14.9	4.7	15.6	4.4	12.3	3.5	16.4	2.9	19.0	2.15	20.1	1.9
78	12.0	6.5	14.4	5.65	15.9	4.7	16.5	4.4	13.5	3.5	17.5	2.9	20.0	2.15	21.0	1.9
75	15.3	6.5	17.3	4.95	18.6	4.2	19.1	4.0	17.0	3.5	20.7	2.75	22.9	2.05	23.7	1.85
73	17.2	5.9	19.2	4.55	20.4	3.95	20.8	3.8	19.2	3.5	22.7	2.65	24.8	2.0	25.5	1.85
70	20.1	5.1	21.9	4.05	23.0	3.6	23.3	3.5	22.4	3.2	25.7	2.5	27.5	1.95	28.1	1.85
68	21.9	4.6	23.7	3.8	24.7	3.4	24.9	3.3	24.4	2.95	27.6	2.4	29.3	1.9	29.7	1.8
65	24.5	3.95	26.2	3.4	27.1	3.1	27.3	3.1	27.4	2.7	30.4	2.25	31.9	1.9	32.1	1.8
63	26.2	3.55	27.9	3.15	28.7	2.95	28.8	2.95	29.3	2.55	32.2	2.2	33.5	1.85	33.6	1.8
60	28.6	2.8	30.2	2.6	30.9	2.5			32.1	2.35	34.7	2.0	35.9	1.8		
58	30.1	2.25	31.6	2.1	32.3	2.05			33.7	1.9	36.3	1.75	37.4	1.65		
55	32.3	1.5	33.7	1.4	34.2	1.4			36.0	1.25	38.4	1.15	39.3	1.1		
53	33.7	1.05	35.0	1.0	35.5	0.95			37.5	0.85	39.7	0.8				
θ(°)	52~81.5		52~81.5		52~81.5		62~81.5		52~81.5		52~81.5		54~81.5		62~81.5	

ジブ長さ	19.0mジブ							
	5°		25°		45°		60°	
オフセット	作業半径m	荷重	作業半径m	荷重	作業半径m	荷重	作業半径m	荷重
81.5	10.2	2.5	15.8	1.3	19.9	0.9	21.8	0.8
80	12.8	2.5	18.2	1.3	22.0	0.9	23.7	0.8
79	14.1	2.5	19.3	1.3	23.1	0.9	24.7	0.8
78	15.4	2.5	20.5	1.3	24.1	0.9	25.6	0.8
75	19.0	2.3	23.8	1.2	27.2	0.9	28.4	0.8
73	21.3	2.1	26.0	1.15	29.1	0.85	30.2	0.75
70	24.7	1.85	29.1	1.1	32.0	0.85	32.7	0.75
68	26.9	1.7	31.2	1.05	33.8	0.8	34.4	0.75
65	30.1	1.55	34.1	1.0	36.4	0.8	36.8	0.75
63	32.2	1.45	36.0	0.95	38.1	0.8	38.3	0.75
60	35.3	1.35	38.8	0.9	40.5	0.75		
58	37.2	1.25	40.6	0.9	42.1	0.75		
55	40.0	1.15	43.1	0.85	44.3	0.75		
53								
θ(°)	54~81.5		54~81.5		54~81.5		62~81.5	

■B性能 48.0mブーム+フルオートジブ (カウンタウエイト 16t
アウトリガ張出幅 7.2m)

単位: t

ジブ長さ	9.0mジブ								14.0mジブ							
	5°		25°		45°		60°		5°		25°		45°		60°	
オフセット	作業半径m	荷重	作業半径m	荷重	作業半径m	荷重	作業半径m	荷重	作業半径m	荷重	作業半径m	荷重	作業半径m	荷重	作業半径m	荷重
81.5	7.9	5.2	10.6	5.0	12.3	4.1	13.0	3.8	9.2	3.5	13.5	2.9	16.4	2.15	17.7	1.9
80	10.1	5.2	12.8	5.0	14.3	4.1	15.0	3.8	11.7	3.5	15.9	2.9	18.5	2.15	19.6	1.9
79	11.3	5.2	13.8	5.0	15.4	4.1	16.0	3.8	12.9	3.5	17.0	2.9	19.6	2.15	20.6	1.9
78	12.4	5.2	14.9	4.95	16.4	4.05	16.9	3.8	14.1	3.5	18.2	2.9	20.6	2.15	21.6	1.9
75	15.7	5.2	17.8	4.2	19.2	3.55	19.6	3.35	17.8	3.5	21.4	2.7	23.6	2.05	24.4	1.85
73	17.8	4.9	19.8	3.8	21.0	3.25	21.4	3.1	20.1	3.5	23.5	2.55	25.6	2.0	26.3	1.85
70	20.7	4.1	22.6	3.3	23.7	2.9	24.0	2.8	23.3	2.95	26.5	2.2	28.4	1.85	28.9	1.75
68	22.6	3.65	24.4	3.0	25.4	2.65	25.7	2.6	25.3	2.65	28.4	2.0	30.2	1.7	30.6	1.65
65	25.4	3.15	27.0	2.6	27.9	2.35	28.1	2.35	28.3	2.25	31.2	1.75	32.8	1.55	33.0	1.5
63	27.1	2.85	28.8	2.4	29.6	2.2	29.6	2.2	30.2	2.05	33.0	1.6	34.4	1.4	34.5	1.4
60	29.7	2.45	31.2	2.1	31.9	1.95			33.1	1.75	35.6	1.4	36.9	1.3		
58	31.3	1.9	32.8	1.85	33.5	1.8			34.9	1.6	37.3	1.3	38.4	1.2		
55	33.5	1.15	34.9	1.15	35.4	1.1			37.2	0.95	39.6	0.9				
θ(°)	54~81.5		54~81.5		54~81.5		62~81.5		54~81.5		54~81.5		57~81.5		62~81.5	

ジブ長さ	19.0mジブ							
	5°		25°		45°		60°	
オフセット	作業半径m	荷重	作業半径m	荷重	作業半径m	荷重	作業半径m	荷重
81.5	10.6	2.2	16.3	1.3	20.3	0.9	22.2	0.8
80	13.2	2.2	18.7	1.3	22.5	0.9	24.2	0.8
79	14.5	2.2	19.9	1.3	23.6	0.9	25.2	0.8
78	15.9	2.2	21.1	1.3	24.7	0.9	26.2	0.8
75	19.7	2.2	24.5	1.2	27.8	0.85	29.1	0.8
73	22.1	2.0	26.8	1.15	29.9	0.85	30.9	0.75
70	25.7	1.8	30.0	1.05	32.8	0.8	33.6	0.75
68	27.9	1.65	32.2	1.05	34.7	0.8	35.3	0.75
65	31.2	1.5	35.2	0.95	37.5	0.8	37.8	0.75
63	33.4	1.4	37.2	0.95	39.2	0.75	39.4	0.75
60	36.5	1.3	40.0	0.9	41.7	0.75		
58	38.5	1.2	41.8	0.85	43.3	0.75		
55								
θ(°)	57~81.5		57~81.5		57~81.5		62~81.5	

フルオートジブ

■ C性能 46.2mブーム+フルオートジブ (カウンタウエイト 21t アウトリガ張出幅 6.36m)

単位: t

ジブ長さ オフセット	9.0mジブ								14.0mジブ							
	5°		25°		45°		60°		5°		25°		45°		60°	
ブーム角度(°)	作業半径m	荷重	作業半径m	荷重	作業半径m	荷重	作業半径m	荷重	作業半径m	荷重	作業半径m	荷重	作業半径m	荷重	作業半径m	荷重
81.5	7.6	6.5	10.2	5.65	12.0	4.7	12.7	4.4	8.8	3.5	13.1	2.9	15.9	2.15	17.2	1.9
80	9.9	6.5	12.3	5.65	13.9	4.7	14.6	4.4	11.2	3.5	15.3	2.9	18.0	2.15	19.1	1.9
79	10.9	6.5	13.4	5.65	14.9	4.7	15.6	4.4	12.3	3.5	16.4	2.9	19.0	2.15	20.1	1.9
78	12.0	6.5	14.4	5.65	15.9	4.7	16.5	4.4	13.5	3.5	17.5	2.9	20.0	2.15	21.0	1.9
75	15.3	6.5	17.3	4.95	18.6	4.2	19.1	4.0	17.0	3.5	20.7	2.75	22.9	2.05	23.7	1.85
73	17.2	5.9	19.2	4.55	20.4	3.95	20.8	3.8	19.2	3.5	22.7	2.65	24.8	2.0	25.5	1.85
70	20.1	5.1	21.9	4.05	23.0	3.6	23.3	3.5	22.4	3.2	25.7	2.5	27.5	1.95	28.1	1.85
68	21.9	4.6	23.7	3.8	24.7	3.4	24.9	3.3	24.4	2.95	27.6	2.4	29.3	1.9	29.7	1.8
65	24.5	3.95	26.2	3.4	27.1	3.1	27.3	3.1	27.4	2.7	30.4	2.25	31.9	1.9	32.1	1.8
63	26.2	3.55	27.9	3.15	28.7	2.95	28.8	2.95	29.3	2.55	32.2	2.2	33.5	1.85	33.6	1.8
60	28.7	3.0	30.3	2.8	31.0	2.65			32.1	2.35	34.7	2.0	35.9	1.8		
58	30.3	2.65	31.8	2.5	32.4	2.4			33.9	2.2	36.4	1.9	37.4	1.75		
55	32.4	1.8	33.8	1.7	34.3	1.65			36.2	1.55	38.5	1.4	39.4	1.35		
53	33.8	1.35	35.1	1.3	35.6	1.25			37.6	1.1	39.9	1.05	40.6	1.0		
50	35.8	0.75														
θ(°)	49~81.5		52~81.5		52~81.5		62~81.5		52~81.5		52~81.5		52~81.5		62~81.5	

ジブ長さ オフセット	19.0mジブ							
	5°		25°		45°		60°	
ブーム角度(°)	作業半径m	荷重	作業半径m	荷重	作業半径m	荷重	作業半径m	荷重
81.5	10.2	2.5	15.8	1.3	19.9	0.9	21.8	0.8
80	12.8	2.5	18.2	1.3	22.0	0.9	23.7	0.8
79	14.1	2.5	19.3	1.3	23.1	0.9	24.7	0.8
78	15.4	2.5	20.5	1.3	24.1	0.9	25.6	0.8
75	19.0	2.3	23.8	1.2	27.2	0.9	28.4	0.8
73	21.3	2.1	26.0	1.15	29.1	0.85	30.2	0.75
70	24.7	1.85	29.1	1.1	32.0	0.85	32.7	0.75
68	26.9	1.7	31.2	1.05	33.8	0.8	34.4	0.75
65	30.1	1.55	34.1	1.0	36.4	0.8	36.8	0.75
63	32.2	1.45	36.0	0.95	38.1	0.8	38.3	0.75
60	35.3	1.35	38.8	0.9	40.5	0.75		
58	37.2	1.25	40.6	0.9	42.1	0.75		
55	40.0	1.15	43.1	0.85	44.3	0.75		
53	41.7	1.05	44.7	0.85	45.6	0.75		
50								
θ(°)	52~81.5		52~81.5		52~81.5		62~81.5	

■ C性能 48.0mブーム+フルオートジブ (カウンタウエイト 21t アウトリガ張出幅 6.36m)

単位: t

ジブ長さ オフセット	9.0mジブ								14.0mジブ							
	5°		25°		45°		60°		5°		25°		45°		60°	
ブーム角度(°)	作業半径m	荷重	作業半径m	荷重	作業半径m	荷重	作業半径m	荷重	作業半径m	荷重	作業半径m	荷重	作業半径m	荷重	作業半径m	荷重
81.5	7.9	5.2	10.6	5.0	12.3	4.1	13.0	3.8	9.2	3.5	13.5	2.9	16.4	2.15	17.7	1.9
80	10.1	5.2	12.8	5.0	14.3	4.1	15.0	3.8	11.7	3.5	15.9	2.9	18.5	2.15	19.6	1.9
79	11.3	5.2	13.8	5.0	15.4	4.1	16.0	3.8	12.9	3.5	17.0	2.9	19.6	2.15	20.6	1.9
78	12.4	5.2	14.9	4.95	16.4	4.05	16.9	3.8	14.1	3.5	18.2	2.9	20.6	2.15	21.6	1.9
75	15.7	5.2	17.8	4.2	19.2	3.55	19.6	3.35	17.8	3.5	21.4	2.7	23.6	2.05	24.4	1.85
73	17.8	4.9	19.8	3.8	21.0	3.25	21.4	3.1	20.1	3.5	23.5	2.55	25.6	2.0	26.3	1.85
70	20.7	4.1	22.6	3.3	23.7	2.9	24.0	2.8	23.3	2.95	26.5	2.2	28.4	1.85	28.9	1.75
68	22.6	3.65	24.4	3.0	25.4	2.65	25.7	2.6	25.3	2.65	28.4	2.0	30.2	1.7	30.6	1.65
65	25.4	3.15	27.0	2.6	27.9	2.35	28.1	2.35	28.3	2.25	31.2	1.75	32.8	1.55	33.0	1.5
63	27.1	2.85	28.8	2.4	29.6	2.2	29.6	2.2	30.2	2.05	33.0	1.6	34.4	1.4	34.5	1.4
60	29.7	2.45	31.2	2.1	31.9	1.95			33.1	1.75	35.6	1.4	36.9	1.3		
58	31.4	2.25	32.9	1.95	33.5	1.85			34.9	1.6	37.3	1.3	38.4	1.2		
55	33.6	1.45	35.0	1.45	35.5	1.4			37.4	1.2	39.7	1.15	40.6	1.1		
53	35.1	1.05	36.4	1.0	36.8	1.0			38.9	0.85						
θ(°)	52~81.5		52~81.5		52~81.5		62~81.5		52~81.5		54~81.5		54~81.5		62~81.5	

ジブ長さ オフセット	19.0mジブ							
	5°		25°		45°		60°	
ブーム角度(°)	作業半径m	荷重	作業半径m	荷重	作業半径m	荷重	作業半径m	荷重
81.5	10.6	2.2	16.3	1.3	20.3	0.9	22.2	0.8
80	13.2	2.2	18.7	1.3	22.5	0.9	24.2	0.8
79	14.5	2.2	19.9	1.3	23.6	0.9	25.2	0.8
78	15.9	2.2	21.1	1.3	24.7	0.9	26.2	0.8
75	19.7	2.2	24.5	1.2	27.8	0.85	29.1	0.8
73	22.1	2.0	26.8	1.15	29.9	0.85	30.9	0.75
70	25.7	1.8	30.0	1.05	32.8	0.8	33.6	0.75
68	27.9	1.65	32.2	1.05	34.7	0.8	35.3	0.75
65	31.2	1.5	35.2	0.95	37.5	0.8	37.8	0.75
63	33.4	1.4	37.2	0.95	39.2	0.75	39.4	0.75
60	36.5	1.3	40.0	0.9	41.7	0.75		
58	38.5	1.2	41.8	0.85	43.3	0.75		
55	41.3	1.05	44.4	0.8	45.6	0.75		
53								
θ(°)	54~81.5		54~81.5		54~81.5		62~81.5	

■ D性能 46.2mブーム+フルオートジブ (カウンタウエイト 16t アウトリガ張出幅 6.36m)

単位: t

ジブ長さ オフセット	9.0mジブ								14.0mジブ							
	5°		25°		45°		60°		5°		25°		45°		60°	
ブーム角度(°)	作業半径m	荷重	作業半径m	荷重	作業半径m	荷重	作業半径m	荷重	作業半径m	荷重	作業半径m	荷重	作業半径m	荷重	作業半径m	荷重
81.5	7.6	6.5	10.2	5.65	12.0	4.7	12.7	4.4	8.8	3.5	13.1	2.9	15.9	2.15	17.2	1.9
80	9.9	6.5	12.3	5.65	13.9	4.7	14.6	4.4	11.2	3.5	15.3	2.9	18.0	2.15	19.1	1.9
79	10.9	6.5	13.4	5.65	14.9	4.7	15.6	4.4	12.3	3.5	16.4	2.9	19.0	2.15	20.1	1.9
78	12.0	6.5	14.4	5.65	15.9	4.7	16.5	4.4	13.5	3.5	17.5	2.9	20.0	2.15	21.0	1.9
75	15.3	6.5	17.3	4.95	18.6	4.2	19.1	4.0	17.0	3.5	20.7	2.75	22.9	2.05	23.7	1.85
73	17.2	5.9	19.2	4.55	20.4	3.95	20.8	3.8	19.2	3.5	22.7	2.65	24.8	2.0	25.5	1.85
70	20.1	5.1	21.9	4.05	23.0	3.6	23.3	3.5	22.4	3.2	25.7	2.5	27.5	1.95	28.1	1.85
68	21.9	4.6	23.7	3.8	24.7	3.4	24.9	3.3	24.4	2.95	27.6	2.4	29.3	1.9	29.7	1.8
65	24.5	3.95	26.2	3.4	27.1	3.1	27.3	3.1	27.4	2.7	30.4	2.25	31.9	1.9	32.1	1.8
63	26.1	3.3	27.9	3.05	28.7	2.9	28.8	2.9	29.3	2.55	32.2	2.2	33.5	1.85	33.6	1.8
60	28.4	2.2	30.0	2.1	30.8	2.0			31.9	1.9	34.6	1.7	35.8	1.6		
58	29.9	1.6	31.4	1.55	32.1	1.45			33.4	1.35	36.0	1.25	37.1	1.15		
θ(°)	57~81.5		57~81.5		57~81.5		62~81.5		57~81.5		57~81.5		57~81.5		62~81.5	

ジブ長さ オフセット	19.0mジブ							
	5°		25°		45°		60°	
ブーム角度(°)	作業半径m	荷重	作業半径m	荷重	作業半径m	荷重	作業半径m	荷重
81.5	10.2	2.5	15.8	1.3	19.9	0.9	21.8	0.8
80	12.8	2.5	18.2	1.3	22.0	0.9	23.7	0.8
79	14.1	2.5	19.3	1.3	23.1	0.9	24.7	0.8
78	15.4	2.5	20.5	1.3	24.1	0.9	25.6	0.8
75	19.0	2.3	23.8	1.2	27.2	0.9	28.4	0.8
73	21.3	2.1	26.0	1.15	29.1	0.85	30.2	0.75
70	24.7	1.85	29.1	1.1	32.0	0.85	32.7	0.75
68	26.9	1.7	31.2	1.05	33.8	0.8	34.4	0.75
65	30.1	1.55	34.1	1.0	36.4	0.8	36.8	0.75
63	32.2	1.45	36.0	0.95	38.1	0.8	38.3	0.75
60	35.3	1.35	38.8	0.9	40.5	0.75		
58	37.2	1.25	40.6	0.9				
θ(°)	57~81.5		57~81.5		59~81.5		62~81.5	

■ D性能 48.0mブーム+フルオートジブ (カウンタウエイト 16t アウトリガ張出幅 6.36m)

単位: t

ジブ長さ オフセット	9.0mジブ								14.0mジブ							
	5°		25°		45°		60°		5°		25°		45°		60°	
ブーム角度(°)	作業半径m	荷重	作業半径m	荷重	作業半径m	荷重	作業半径m	荷重	作業半径m	荷重	作業半径m	荷重	作業半径m	荷重	作業半径m	荷重
81.5	7.9	5.2	10.6	5.0	12.3	4.1	13.0	3.8	9.2	3.5	13.5	2.9	16.4	2.15	17.7	1.9
80	10.1	5.2	12.8	5.0	14.3	4.1	15.0	3.8	11.7	3.5	15.9	2.9	18.5	2.15	19.6	1.9
79	11.3	5.2	13.8	5.0	15.4	4.1	16.0	3.8	12.9	3.5	17.0	2.9	19.6	2.15	20.6	1.9
78	12.4	5.2	14.9	4.95	16.4	4.05	16.9	3.8	14.1	3.5	18.2	2.9	20.6	2.15	21.6	1.9
75	15.7	5.2	17.8	4.2	19.2	3.55	19.6	3.35	17.8	3.5	21.4	2.7	23.6	2.05	24.4	1.85
73	17.8	4.9	19.8	3.8	21.0	3.25	21.4	3.1	20.1	3.5	23.5	2.55	25.6	2.0	26.3	1.85
70	20.7	4.1	22.6	3.3	23.7	2.9	24.0	2.8	23.3	2.95	26.5	2.2	28.4	1.85	28.9	1.75
68	22.6	3.65	24.4	3.0	25.4	2.65	25.7	2.6	25.3	2.65	28.4	2.0	30.2	1.7	30.6	1.65
65	25.4	3.15	27.0	2.6	27.9	2.35	28.1	2.35	28.3	2.25	31.2	1.75	32.8	1.55	33.0	1.5
63	27.1	2.85	28.8	2.4	29.6	2.2	29.6	2.2	30.2	2.05	33.0	1.6	34.4	1.4	34.5	1.4
60	29.5	1.85	31.1	1.8	31.8	1.7			32.9	1.55	35.6	1.4	36.9	1.3		
58			32.5	1.25												
θ(°)	59~81.5		57~81.5		59~81.5		62~81.5		59~81.5		59~81.5		59~81.5		62~81.5	

ジブ長さ オフセット	19.0mジブ							
	5°		25°		45°		60°	
ブーム角度(°)	作業半径m	荷重	作業半径m	荷重	作業半径m	荷重	作業半径m	荷重
81.5	10.6	2.2	16.3	1.3	20.3	0.9	22.2	0.8
80	13.2	2.2	18.7	1.3	22.5	0.9	24.2	0.8
79	14.5	2.2	19.9	1.3	23.6	0.9	25.2	0.8
78	15.9	2.2	21.1	1.3	24.7	0.9	26.2	0.8
75	19.7	2.2	24.5	1.2	27.8	0.85	29.1	0.8
73	22.1	2.0	26.8	1.15	29.9	0.85	30.9	0.75
70	25.7	1.8	30.0	1.05	32.8	0.8	33.6	0.75
68	27.9	1.65	32.2	1.05	34.7	0.8	35.3	0.75
65	31.2	1.5	35.2	0.95	37.5	0.8	37.8	0.75
63	33.4	1.4	37.2	0.95	39.2	0.75	39.4	0.75
60	36.5	1.3	40.0	0.9	41.7	0.75		
58								
θ(°)	59~81.5		59~81.5		59~81.5		62~81.5	

フルオートジブ

■E性能 46.2mブーム+フルオートジブ (カウンタウエイト 9t) (アウトリガ張出幅 7.2m) (カウンタウエイト 21t) (アウトリガ張出幅 4.9m)

単位: t

ジブ長さ	9.0mジブ								14.0mジブ							
	5°		25°		45°		60°		5°		25°		45°		60°	
オフセット	作業半径m	荷重	作業半径m	荷重	作業半径m	荷重	作業半径m	荷重	作業半径m	荷重	作業半径m	荷重	作業半径m	荷重	作業半径m	荷重
81.5	7.6	6.5	10.2	5.65	12.0	4.7	12.7	4.4	8.8	3.5	13.1	2.9	15.9	2.15	17.2	1.9
80	9.9	6.5	12.3	5.65	13.9	4.7	14.6	4.4	11.2	3.5	15.3	2.9	18.0	2.15	19.1	1.9
79	10.9	6.5	13.4	5.65	14.9	4.7	15.6	4.4	12.3	3.5	16.4	2.9	19.0	2.15	20.1	1.9
78	12.0	6.5	14.4	5.65	15.9	4.7	16.5	4.4	13.5	3.5	17.5	2.9	20.0	2.15	21.0	1.9
75	15.3	6.5	17.3	4.95	18.6	4.2	19.1	4.0	17.0	3.5	20.7	2.75	22.9	2.05	23.7	1.85
73	17.2	5.9	19.2	4.55	20.4	3.95	20.8	3.8	19.2	3.5	22.7	2.65	24.8	2.0	25.5	1.85
70	20.1	5.1	21.9	4.05	23.0	3.6	23.3	3.5	22.4	3.2	25.7	2.5	27.5	1.95	28.1	1.85
68	21.7	4.05	23.6	3.7	24.7	3.4	24.9	3.3	24.4	2.95	27.6	2.4	29.3	1.9	29.7	1.8
65	24.1	2.8	25.9	2.6	26.9	2.45	27.1	2.4	27.2	2.4	30.3	2.1	31.9	1.9	32.1	1.8
63	25.7	2.15	27.5	2.0	28.4	1.9	28.4	1.85	28.9	1.8	31.8	1.6	33.4	1.5	33.5	1.5
θ(°)	62~81.5		62~81.5		62~81.5		62~81.5		62~81.5		62~81.5		62~81.5		62~81.5	

ジブ長さ	19.0mジブ							
	5°		25°		45°		60°	
オフセット	作業半径m	荷重	作業半径m	荷重	作業半径m	荷重	作業半径m	荷重
81.5	10.2	2.5	15.8	1.3	19.9	0.9	21.8	0.8
80	12.8	2.5	18.2	1.3	22.0	0.9	23.7	0.8
79	14.1	2.5	19.3	1.3	23.1	0.9	24.7	0.8
78	15.4	2.5	20.5	1.3	24.1	0.9	25.6	0.8
75	19.0	2.3	23.8	1.2	27.2	0.9	28.4	0.8
73	21.3	2.1	26.0	1.15	29.1	0.85	30.2	0.75
70	24.7	1.85	29.1	1.1	32.0	0.85	32.7	0.75
68	26.9	1.7	31.2	1.05	33.8	0.8	34.4	0.75
65	30.1	1.55	34.1	1.0	36.4	0.8	36.8	0.75
63	32.2	1.45	36.0	0.95	38.1	0.8	38.3	0.75
θ(°)	62~81.5		62~81.5		62~81.5		62~81.5	

■E性能 48.0mブーム+フルオートジブ (カウンタウエイト 9t) (アウトリガ張出幅 7.2m) (カウンタウエイト 21t) (アウトリガ張出幅 4.9m)

単位: t

ジブ長さ	9.0mジブ								14.0mジブ							
	5°		25°		45°		60°		5°		25°		45°		60°	
オフセット	作業半径m	荷重	作業半径m	荷重	作業半径m	荷重	作業半径m	荷重	作業半径m	荷重	作業半径m	荷重	作業半径m	荷重	作業半径m	荷重
81.5	7.9	5.2	10.6	5.0	12.3	4.1	13.0	3.8	9.2	3.5	13.5	2.9	16.4	2.15	17.7	1.9
80	10.1	5.2	12.8	5.0	14.3	4.1	15.0	3.8	11.7	3.5	15.9	2.9	18.5	2.15	19.6	1.9
79	11.3	5.2	13.8	5.0	15.4	4.1	16.0	3.8	12.9	3.5	17.0	2.9	19.6	2.15	20.6	1.9
78	12.4	5.2	14.9	4.95	16.4	4.05	16.9	3.8	14.1	3.5	18.2	2.9	20.6	2.15	21.6	1.9
75	15.7	5.2	17.8	4.2	19.2	3.55	19.6	3.35	17.8	3.5	21.4	2.7	23.6	2.05	24.4	1.85
73	17.8	4.9	19.8	3.8	21.0	3.25	21.4	3.1	20.1	3.5	23.5	2.55	25.6	2.0	26.3	1.85
70	20.7	4.1	22.6	3.3	23.7	2.9	24.0	2.8	23.3	2.95	26.5	2.2	28.4	1.85	28.9	1.75
68	22.6	3.6	24.4	3.0	25.4	2.65	25.7	2.6	25.3	2.65	28.4	2.0	30.2	1.7	30.6	1.65
65	25.1	2.45	26.9	2.3	27.9	2.2	28.0	2.15	28.2	2.05	31.2	1.75	32.8	1.55	33.0	1.5
63	26.7	1.8	28.5	1.75	29.4	1.65	29.4	1.65	29.9	1.5	32.8	1.35	34.3	1.25	34.5	1.25
θ(°)	62~81.5		62~81.5		62~81.5		62~81.5		62~81.5		62~81.5		62~81.5		62~81.5	

ジブ長さ	19.0mジブ							
	5°		25°		45°		60°	
オフセット	作業半径m	荷重	作業半径m	荷重	作業半径m	荷重	作業半径m	荷重
81.5	10.6	2.2	16.3	1.3	20.3	0.9	22.2	0.8
80	13.2	2.2	18.7	1.3	22.5	0.9	24.2	0.8
79	14.5	2.2	19.9	1.3	23.6	0.9	25.2	0.8
78	15.9	2.2	21.1	1.3	24.7	0.9	26.2	0.8
75	19.7	2.2	24.5	1.2	27.8	0.85	29.1	0.8
73	22.1	2.0	26.8	1.15	29.9	0.85	30.9	0.75
70	25.7	1.8	30.0	1.05	32.8	0.8	33.6	0.75
68	27.9	1.65	32.2	1.05	34.7	0.8	35.3	0.75
65	31.2	1.5	35.2	0.95	37.5	0.8	37.8	0.75
63								
θ(°)	64~81.5		64~81.5		64~81.5		64~81.5	

■ F性能 46.2mブーム+フルオートジブ (カウンタウエイト 9t) (カウンタウエイト 16t)
 (アウトリガ張出幅 6.36m) (アウトリガ張出幅 4.9m) 単位: t

ジブ長さ オフセット	9.0mジブ								14.0mジブ							
	5°		25°		45°		60°		5°		25°		45°		60°	
ブーム角度(°)	作業半径m	荷重	作業半径m	荷重	作業半径m	荷重	作業半径m	荷重	作業半径m	荷重	作業半径m	荷重	作業半径m	荷重	作業半径m	荷重
81.5	7.6	6.5	10.2	5.65	12.0	4.7	12.7	4.4	8.8	3.5	13.1	2.9	15.9	2.15	17.2	1.9
80	9.9	6.5	12.3	5.65	13.9	4.7	14.6	4.4	11.2	3.5	15.3	2.9	18.0	2.15	19.1	1.9
79	10.9	6.5	13.4	5.65	14.9	4.7	15.6	4.4	12.3	3.5	16.4	2.9	19.0	2.15	20.1	1.9
78	12.0	6.5	14.4	5.65	15.9	4.7	16.5	4.4	13.5	3.5	17.5	2.9	20.0	2.15	21.0	1.9
75	15.3	6.5	17.3	4.95	18.6	4.2	19.1	4.0	17.0	3.5	20.7	2.75	22.9	2.05	23.7	1.85
73	17.2	5.9	19.2	4.55	20.4	3.95	20.8	3.8	19.2	3.5	22.7	2.65	24.8	2.0	25.5	1.85
70	19.8	4.4	21.9	4.0	23.0	3.6	23.3	3.5	22.4	3.2	25.7	2.5	27.5	1.95	28.1	1.85
68	21.4	3.3	23.4	3.0	24.5	2.8	24.7	2.75	24.3	2.8	27.6	2.4	29.3	1.9	29.7	1.8
θ(°)	67~81.5		67~81.5		67~81.5		67~81.5		67~81.5		67~81.5		67~81.5		67~81.5	

ジブ長さ オフセット	19.0mジブ							
	5°		25°		45°		60°	
ブーム角度(°)	作業半径m	荷重	作業半径m	荷重	作業半径m	荷重	作業半径m	荷重
81.5	10.2	2.5	15.8	1.3	19.9	0.9	21.8	0.8
80	12.8	2.5	18.2	1.3	22.0	0.9	23.7	0.8
79	14.1	2.5	19.3	1.3	23.1	0.9	24.7	0.8
78	15.4	2.5	20.5	1.3	24.1	0.9	25.6	0.8
75	19.0	2.3	23.8	1.2	27.2	0.9	28.4	0.8
73	21.3	2.1	26.0	1.15	29.1	0.85	30.2	0.75
70	24.7	1.85	29.1	1.1	32.0	0.85	32.7	0.75
68	26.9	1.7	31.2	1.05	33.8	0.8	34.4	0.75
θ(°)	67~81.5		67~81.5		67~81.5		67~81.5	

■ F性能 48.0mブーム+フルオートジブ (カウンタウエイト 9t) (カウンタウエイト 16t)
 (アウトリガ張出幅 6.36m) (アウトリガ張出幅 4.9m) 単位: t

ジブ長さ オフセット	9.0mジブ								14.0mジブ							
	5°		25°		45°		60°		5°		25°		45°		60°	
ブーム角度(°)	作業半径m	荷重	作業半径m	荷重	作業半径m	荷重	作業半径m	荷重	作業半径m	荷重	作業半径m	荷重	作業半径m	荷重	作業半径m	荷重
81.5	7.9	5.2	10.6	5.0	12.3	4.1	13.0	3.8	9.2	3.5	13.5	2.9	16.4	2.15	17.7	1.9
80	10.1	5.2	12.8	5.0	14.3	4.1	15.0	3.8	11.7	3.5	15.9	2.9	18.5	2.15	19.6	1.9
79	11.3	5.2	13.8	5.0	15.4	4.1	16.0	3.8	12.9	3.5	17.0	2.9	19.6	2.15	20.6	1.9
78	12.4	5.2	14.9	4.95	16.4	4.05	16.9	3.8	14.1	3.5	18.2	2.9	20.6	2.15	21.6	1.9
75	15.7	5.2	17.8	4.2	19.2	3.55	19.6	3.35	17.8	3.5	21.4	2.7	23.6	2.05	24.4	1.85
73	17.8	4.9	19.8	3.8	21.0	3.25	21.4	3.1	20.1	3.5	23.5	2.55	25.6	2.0	26.3	1.85
70	20.6	3.9	22.6	3.3	23.7	2.9	24.0	2.8	23.3	2.95	26.5	2.2	28.4	1.85	28.9	1.75
68	22.3	2.85	24.3	2.7	25.4	2.5	25.6	2.5	25.2	2.4	28.4	2.0	30.2	1.7	30.6	1.65
θ(°)	67~81.5		67~81.5		67~81.5		67~81.5		67~81.5		67~81.5		67~81.5		67~81.5	

ジブ長さ オフセット	19.0mジブ							
	5°		25°		45°		60°	
ブーム角度(°)	作業半径m	荷重	作業半径m	荷重	作業半径m	荷重	作業半径m	荷重
81.5	10.6	2.2	16.3	1.3	20.3	0.9	22.2	0.8
80	13.2	2.2	18.7	1.3	22.5	0.9	24.2	0.8
79	14.5	2.2	19.9	1.3	23.6	0.9	25.2	0.8
78	15.9	2.2	21.1	1.3	24.7	0.9	26.2	0.8
75	19.7	2.2	24.5	1.2	27.8	0.85	29.1	0.8
73	22.1	2.0	26.8	1.15	29.9	0.85	30.9	0.75
70	25.7	1.8	30.0	1.05	32.8	0.8	33.6	0.75
68	27.9	1.65	32.2	1.05				
θ(°)	67~81.5		67~81.5		69~81.5		69~81.5	

フルオートジブ

■ G性能 46.2mブーム+フルオートジブ (カウンタウエイト 9t アウトリガ張出幅 4.9m)

単位：t

ジブ長さ オフセット	9.0mジブ								14.0mジブ							
	5°		25°		45°		60°		5°		25°		45°		60°	
ブーム角度(°)	作業半径m	荷重	作業半径m	荷重	作業半径m	荷重	作業半径m	荷重	作業半径m	荷重	作業半径m	荷重	作業半径m	荷重	作業半径m	荷重
81.5	7.6	6.5	10.2	5.65	12.0	4.7	12.7	4.4	8.8	3.5	13.1	2.9	15.9	2.15	17.2	1.9
80	9.9	6.5	12.3	5.65	13.9	4.7	14.6	4.4	11.2	3.5	15.3	2.9	18.0	2.15	19.1	1.9
79	10.9	6.5	13.4	5.65	14.9	4.7	15.6	4.4	12.3	3.5	16.4	2.9	19.0	2.15	20.1	1.9
78	12.0	6.5	14.4	5.65	15.9	4.7	16.5	4.4	13.5	3.5	17.5	2.9	20.0	2.15	21.0	1.9
75	15.1	5.9	17.3	4.95	18.6	4.2	19.1	4.0	17.0	3.5	20.7	2.75	22.9	2.05	23.7	1.85
73	16.8	4.25	18.9	3.75	20.2	3.4	20.7	3.3	19.2	3.5	22.7	2.65	24.8	2.0	25.5	1.85
θ(°)	72~81.5		72~81.5		72~81.5		72~81.5		72~81.5		72~81.5		72~81.5		72~81.5	

ジブ長さ オフセット	19.0mジブ							
	5°		25°		45°		60°	
ブーム角度(°)	作業半径m	荷重	作業半径m	荷重	作業半径m	荷重	作業半径m	荷重
81.5	10.2	2.5	15.8	1.3	19.9	0.9	21.8	0.8
80	12.8	2.5	18.2	1.3	22.0	0.9	23.7	0.8
79	14.1	2.5	19.3	1.3	23.1	0.9	24.7	0.8
78	15.4	2.5	20.5	1.3	24.1	0.9	25.6	0.8
75	19.0	2.3	23.8	1.2	27.2	0.9	28.4	0.8
73	21.3	2.1	26.0	1.15				
θ(°)	72~81.5		72~81.5		74~81.5		74~81.5	

■ G性能 48.0mブーム+フルオートジブ (カウンタウエイト 9t アウトリガ張出幅 4.9m)

単位：t

ジブ長さ オフセット	9.0mジブ								14.0mジブ							
	5°		25°		45°		60°		5°		25°		45°		60°	
ブーム角度(°)	作業半径m	荷重	作業半径m	荷重	作業半径m	荷重	作業半径m	荷重	作業半径m	荷重	作業半径m	荷重	作業半径m	荷重	作業半径m	荷重
81.5	7.9	5.2	10.6	5.0	12.3	4.1	13.0	3.8	9.2	3.5	13.5	2.9	16.4	2.15	17.7	1.9
80	10.1	5.2	12.8	5.0	14.3	4.1	15.0	3.8	11.7	3.5	15.9	2.9	18.5	2.15	19.6	1.9
79	11.3	5.2	13.8	5.0	15.4	4.1	16.0	3.8	12.9	3.5	17.0	2.9	19.6	2.15	20.6	1.9
78	12.4	5.2	14.9	4.95	16.4	4.05	16.9	3.8	14.1	3.5	18.2	2.9	20.6	2.15	21.6	1.9
75	15.7	5.2	17.8	4.2	19.2	3.55	19.6	3.35	17.8	3.5	21.4	2.7	23.6	2.05	24.4	1.85
73	17.4	3.65	19.6	3.35	20.9	3.05	21.4	3.0								
θ(°)	72~81.5		72~81.5		72~81.5		72~81.5		74~81.5		74~81.5		74~81.5		74~81.5	

ジブ長さ オフセット	19.0mジブ							
	5°		25°		45°		60°	
ブーム角度(°)	作業半径m	荷重	作業半径m	荷重	作業半径m	荷重	作業半径m	荷重
81.5	10.6	2.2	16.3	1.3	20.3	0.9	22.2	0.8
80	13.2	2.2	18.7	1.3	22.5	0.9	24.2	0.8
79	14.5	2.2	19.9	1.3	23.6	0.9	25.2	0.8
78	15.9	2.2	21.1	1.3	24.7	0.9	26.2	0.8
75	19.7	2.2	24.5	1.2	27.8	0.85	29.1	0.8
73								
θ(°)	74~81.5		74~81.5		74~81.5		74~81.5	